

Installation Note

**Agilent Technologies ESG-D and ESG-DP Series
Signal Generators Option UND Upgrade
Kit Part Numbers E4400-60166 and E4400-60181**

**Models: E4430B, E4431B, E4432B, E4433B, E4434B,
E4435B, E4436B and E4437B**



Part Number E4400-90214
Printed in USA October 2004
Supersedes July 2000



E4400-90214

Notice.

The information contained in this document is subject to change without notice.

Agilent Technologies makes no warranty of any kind with regard to this material, including but not limited to, the implied warranties of merchantability and fitness for a particular purpose. Agilent Technologies shall not be liable for errors contained herein or for incidental or consequential damages in connection with the furnishing, performance, or use of this material.

Standard ESG-D to Option UND Upgrade Kit

Product Affected:	ESG-D and ESG-DP Series Signal Generators
Models Affected:	E4430B, E4431B, E4432B, E4433B, E4434B, E4435B, E4436B and E4437B
Serial Numbers:	All
To Be Performed By:	(X) Agilent Service Center (X) Personnel Qualified by Agilent Technologies (X) Customer
Estimated Installation Time:	1.5 hours
Estimated Verification Time:	0.5 hour

Introduction

This installation note contains instructions for installing Option UND, the dual arbitrary waveform generator, in a standard ESG-D or ESG-DP signal generator. This note applies to two kits. The kit used is determined by the options installed. The kits are identified and described below.

Kit Part Number	Description
E4400-60166	Installs Option UND in signal generators without Options UN3/4 or UN8/9 installed.
E4400-60181	Installs Options UND in signal generators equipped with Option UN3/4 or UN8/9.

Perform this installation in its entirety and in the order presented.

Upgrade Kit E4400-60166 (For Signal Generators without Options UN3/4 or UN8/9)

The tools and kit contents required to install the Option UND upgrade for signal generators *not* equipped with Options UN3/4 or UN8/9 are described below.

Tools Required

- T-10 TORX screwdriver
- T-15 TORX screwdriver
- Break away torque wrench, 9 in-lbs
- Ratchet, 21 in-lbs
- Socket, 9/16
- Socket, 3/8
- Hand torque driver, 9 in-lbs, socket 9/32
- Hand torque driver, 6 in-lbs, socket 3/16
- Scissors

WARNING

Before you disassemble the signal generator, turn the power switch off and disconnect the line cord. Failure to unplug the signal generator can result in personal injury.

CAUTION

Electrostatic discharge (ESD) can damage or destroy electronic components. All work on electronic assemblies should be performed at a static-safe workstation.

Upgrade Kit E4400-60166 Contents

Item	Quantity		Description	Part Number
	Std (No Opt's ^a)	UN7		
1	1	0	This installation note	E4400-90214
2	1	1	Dual arbitrary waveform generator board	E4400-60187
3	1	0	Rear-panel interface board	E4400-60145
4	1	0	Rear panel (Option UND)	E4400-00031
5	1	0	W3, DATA to motherboard or DATA to Data Generator (A8J2) (Option UN3/4 or UN8/9)	8120-5063
6	1	0	W4, DATA CLOCK to motherboard or DATA CLOCK to Data Generator (A8J1) (Option UN3/4 or UN8/9)	8120-5063
7	1	0	W5, SYMBOL SYNC to motherboard or SYMBOL SYNC to Data Generator (A8J3) (Option UN3/4 or UN8/9)	8120-5063
8	1	0	W15, dual arbitrary waveform generator (A5J3) to BASEBAND GEN REF IN (13 MHz)	8120-5055
9	1	0	W16, dual arbitrary waveform generator (A5J2) to Q OUT	8120-5055
10	1	0	W17, dual arbitrary waveform generator (A5J1) to I OUT	8120-5055
11	1	0	W18, rear-panel interface board (A17) to dual arbitrary waveform generator (A5P1) ribbon cable	8120-8458
12	1	1	W24, for future use with Options UND and UN3/4 or Options UND and UN8/9	E4400-20131
13	11	0	Washer, lock 0.4721D	2190-0102
14	3	0	Washer, lock 0.4091D	3050-1919
15	14	0	Nut, hex 15/32-32	2950-0035
16	3	0	Plug, hole 0.500D	6960-0002
17	1	0	Label, Option UND serial number	7120-1232
18	1	0	Label, front-panel overlay-connectors (Option UND)	E4400-80006
19	1	0	Safety solvent cleaner	8500-6269
20	1	0	Firmware Upgrade Kit	E4400-60230
21	1	0	W25, INT Q coax cable A14P103 to Daughter board A15J8	8120-8748
22	1	0	W26, INT I coax cable A14P102 to Daughter board A15J9	8120-8748
23 ^b	1	0	W25, INT Q coax cable A14P103 to Daughter board A15J8	8120-8781
24 ^b	1	0	W26, INT I coax cable A14P102 to Daughter board A15J9	8120-8781

a Implies no other digital hardware installed.

b For ESG-DP Models E4434B, E4435B, E4436B and E4437B.

Upgrade Kit E4400-60181 (For Signal Generators Equipped with Options UN3/4 or UN8/9)

The tools and kit contents required to install the Option UND upgrade for signal generators equipped with Options UN3/4 or UN8/9 are described below.

Tools Required

- T-10 TORX screwdriver
- T-15 TORX screwdriver
- Scissors

WARNING Before you disassemble the signal generator, turn the power switch off and disconnect the line cord. Failure to unplug the signal generator can result in personal injury.

CAUTION Electrostatic discharge (ESD) can damage or destroy electronic components. All work on electronic assemblies should be performed at a static-safe workstation.

Upgrade Kit E4400-60181 Contents

Item	Quantity			Description	Part Number
	Std (No Opt's)	UN7	UN3/4 or UN8/9		
1	1	0	0	This installation note	E4400-90214
2	1	1	1	Dual arbitrary waveform generator board	E4400-60187
3	1	1	1	W24, baseband generator-13 MHz (A7J3) to dual arbitrary waveform generator-13 MHz (A5J4)	E4400-20131
4	1	0	0	Label, Option UND serial number	7120-1232
5	1	0	0	Firmware Upgrade Kit	E4400-60230
6	1	0	0	W25, INT Q coax cable A14P103 to Daughter board A15J8	8120-8748
7	1	0	0	W26, INT I coax cable A14P102 to Daughter board A15J9	8120-8748
8 ^a	1	0	0	W25, INT Q coax cable A14P103 to Daughter board A15J8	8120-8781
9 ^a	1	0	0	W26, INT I coax cable A14P102 to Daughter board A15J9	8120-8781

^a For ESG-DP Models E4434B, E4435B, E4436B and E4437B.

Functionality Check

This procedure verifies that the signal generator powers up and that the internal instrument check does not identify any errors. The internal check returns an error message if a problem is detected.

1. Turn the signal generator's power switch on. The green LED will light. Let the signal generator warm up for 5 minutes.
2. Cycle the power to the signal generator. The green LED lights again and the signal generator performs a check.
3. When the display is illuminated, check to see if the `ERR` annunciator is displayed.

NOTE For signal generators with Option 1E5, `ERROR 514, Reference Oven Cold` will occur whenever the signal generator is first connected to the AC line power. This error cannot be cleared from the error queue until the internal reference has warmed up (approximately 5 minutes).

4. If the `ERR` annunciator is displayed, review the error messages in the queue by pressing **Utility > Error Info**. The first error message in the queue will be shown in the text area of the display. Refer to the service guide for information about the error message.

If there is more than one error message (each message will be designated as 1 of *n*, 2 of *n*, etc.), continue pressing the **View Next Error Message** softkey until you have seen all of the messages.

5. When you have resolved all of the error messages, press **Clear Error Queue(s)** to delete the messages, then restart this procedure at step two.

Installation Procedure

Remove the signal generator covers

1. Turn the signal generator's power switch off and disconnect the line cord.
2. Refer to Figure 1 on page 8. Remove the four bottom feet (item 3).
3. Remove the two strap handles (item 1) from each side of the signal generator by loosening the two screws (item 2) on each handle.
4. Remove the four rear feet (item 4) from the signal generator by removing the four screws (item 5) that secure them.
5. Slide the signal generator top cover (item 6) off the back of the signal generator.
6. Refer to Figure 2 on page 9. Remove the 11 screws (item 1) that secure the top chassis cover (item 2) and remove it.
7. If Options UN3/4 or UN8/9 are installed, proceed to "Install the Option UND Board Assembly (Options UN3/4 or UN8/9 Installed)" on page 17.

Figure 1 **Top Cover Removal**

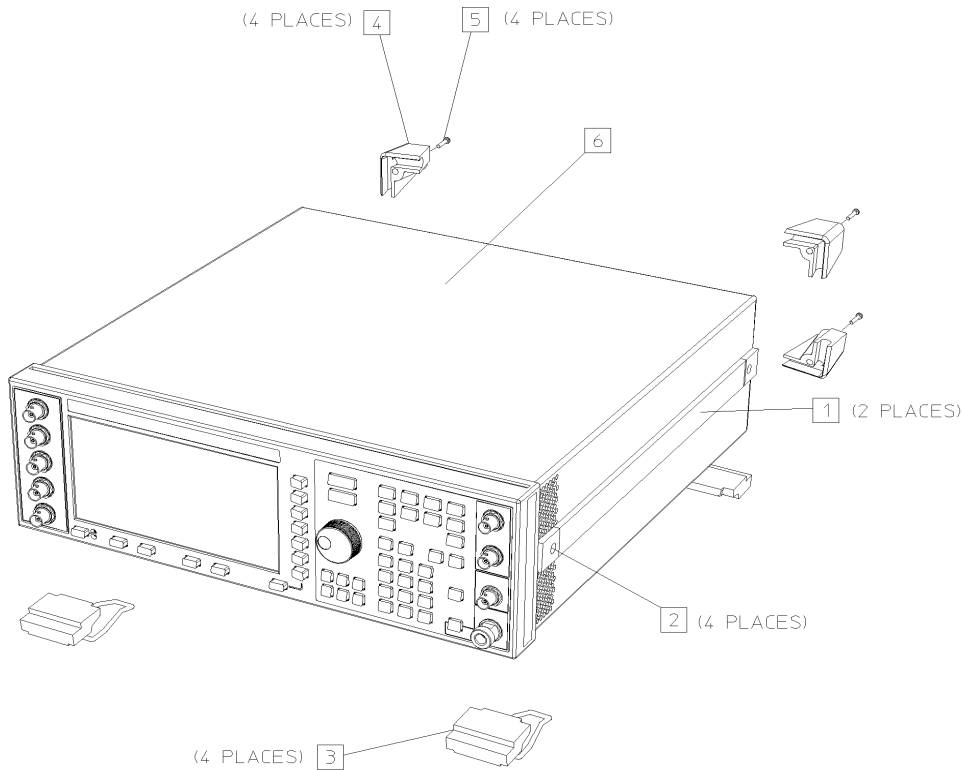

sk795a

Figure 2

Top Chassis Cover Removal

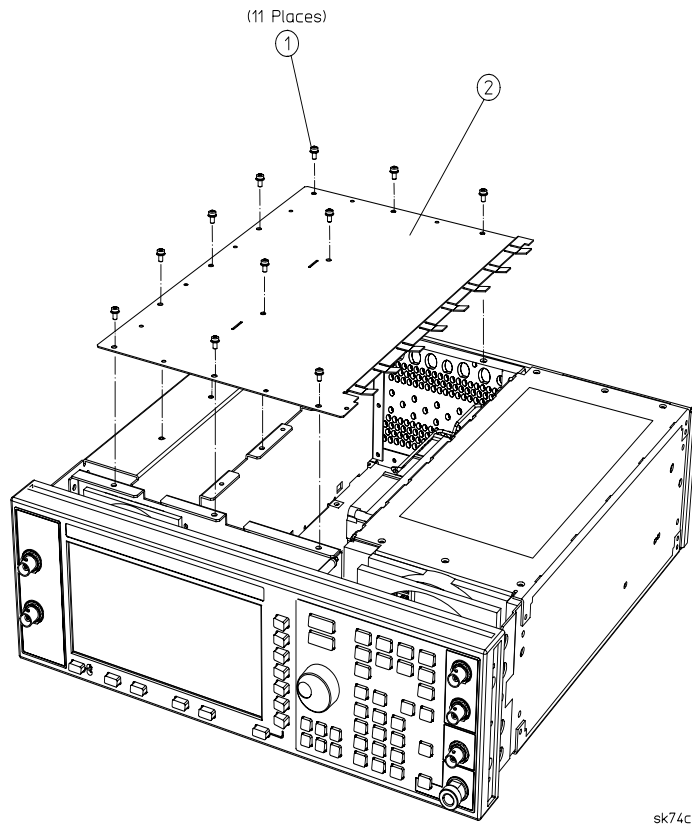

Remove the Standard Signal Generator Rear Panel

1. Refer to Figure 3 on page 10. Remove the 15 screws (item 2) that secure the bottom chassis cover (item 3) and lift the chassis cover off.
2. Refer to Figure 4 on page 11. Disconnect A16W1 from the power supply (A4). Access to A16W1 can be gained through an opening in the bottom of the power supply shield (item 1, Figure 3).

Figure 3

Bottom Chassis Cover Removal

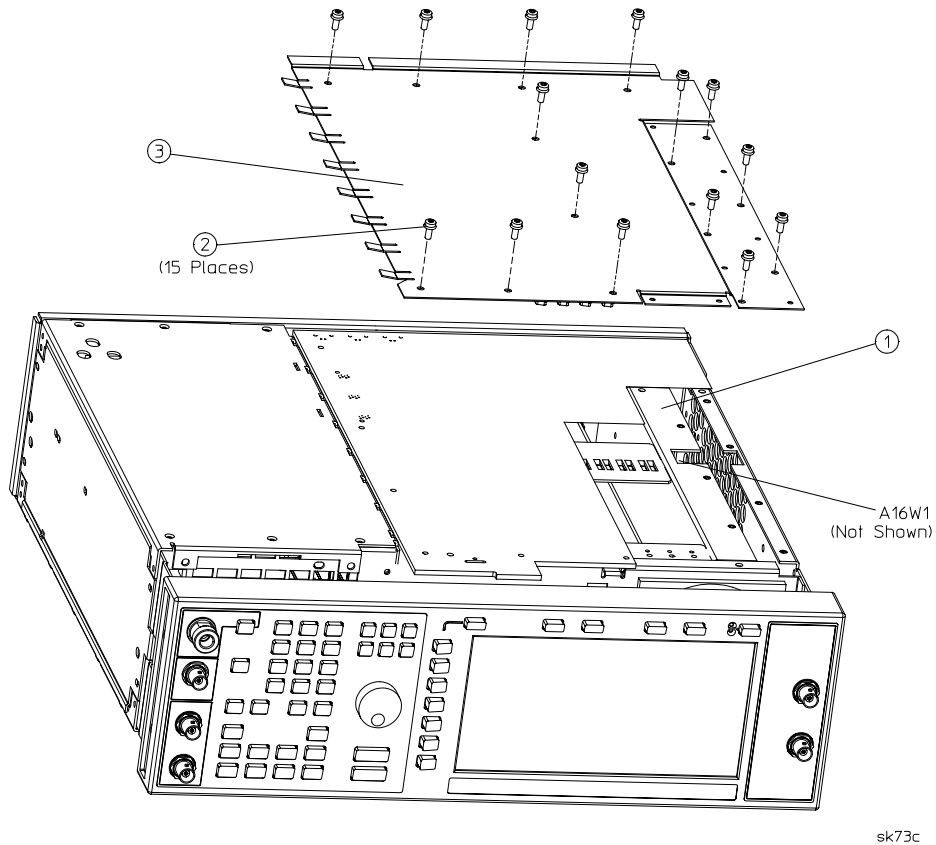

3. Refer to Figure 4 on page 11. Remove the nuts and washers that secure the five BNC connectors (item 2).
4. Remove the hex screws and washers that secure the AUXILIARY INTERFACE (item 3) and GPIB (item 4) connectors to the rear panel.
5. Remove the 10 screws (item 5) that secure the rear panel to the signal generator chassis.
6. Remove the two screws and the bracket from top of the rear chassis. Save the bracket.
7. Disconnect the COHERENT CARRIER CABLE (W12) from the rear panel.
8. Pull the rear panel assembly away from the signal generator chassis.

Figure 4 Removing the Rear Panel and Rear Panel Parts

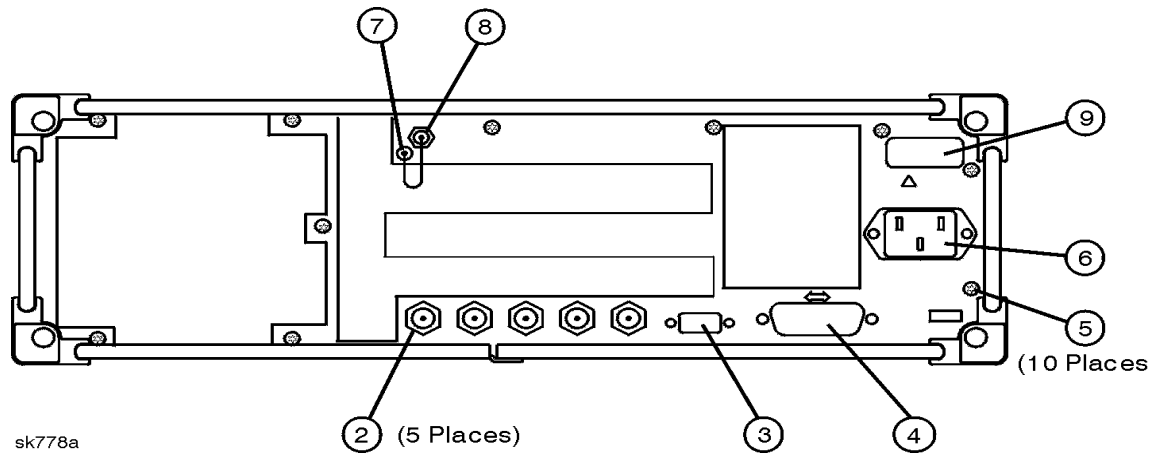
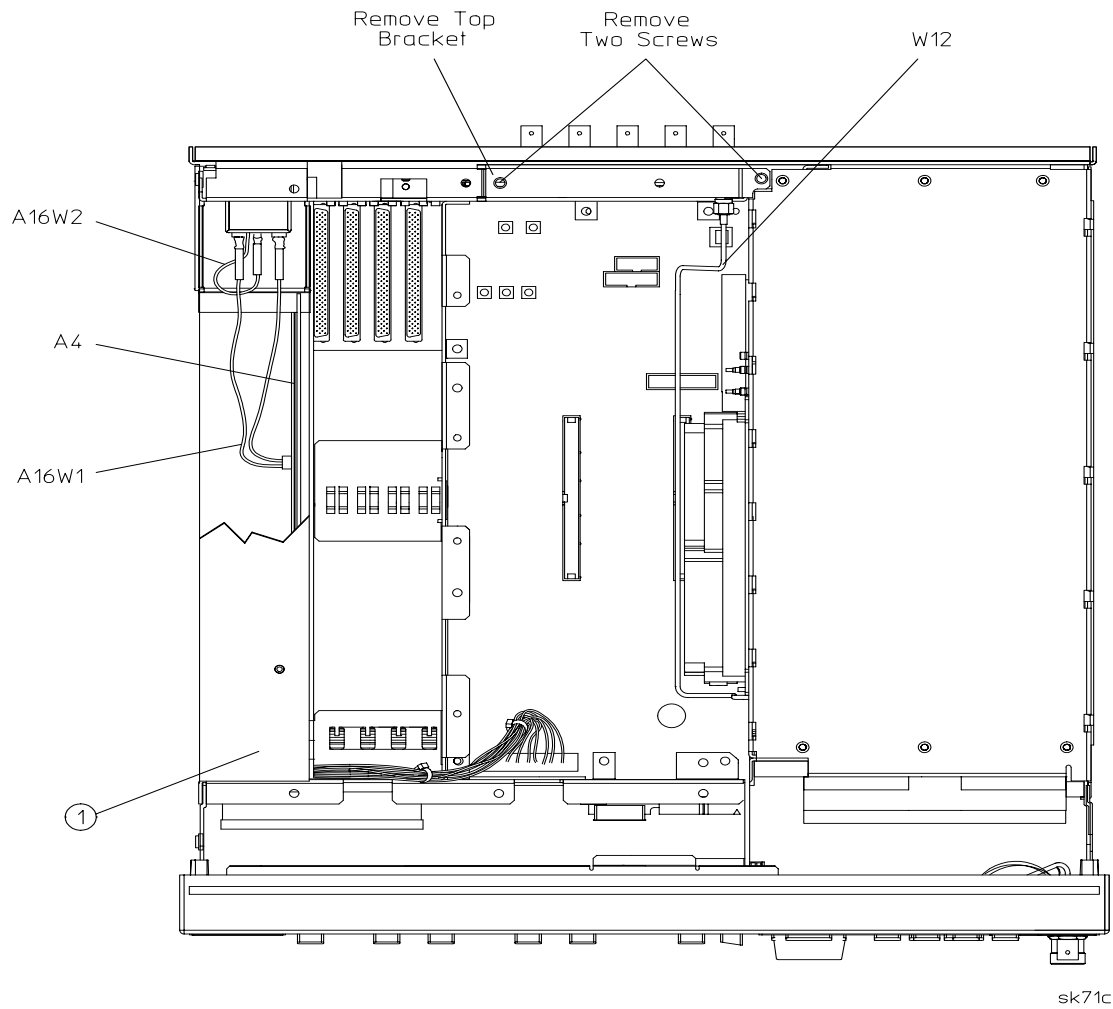

Removing Rear Panel Parts

1. Refer to Figure 4 on page 11. Remove the nut (not shown) that attaches the green ground wire (A16W2) to the rear panel and remove the screws securing the line module (item 6).
2. Remove the chain screw securing the COHERANT CARRIER dust cap (item 7).
3. Remove the nut (not shown) from the COHERANT CARRIER connector (item 8) and remove the RF connector.
4. Remove the nut (not shown) securing the serial tag (item 9) and remove the serial tag.

Assemble the Option UND Rear Panel

1. Refer to Figure 5 on page 13. Attach the A17 rear-panel interface to the Option UND rear panel with the eight washers and hex nuts. Torque to 21 in-lbs.
2. Refer to Figure 4 on page 11. Assemble the COHERANT CARRIER connector to the rear panel using the washer and hex nut. Torque to 21 in-lbs.
3. Attach the COHERANT CARRIER cap and chain screw to the rear panel. Torque to 9 in-lbs.
4. Insert W15 into the rear-panel hole for the BASEBAND GEN REF IN connector. Secure the cable using a washer and hex nut. Torque to 21 in-lbs.
5. Insert W16 into the rear-panel hole for the Q-OUT connector. Secure the cable using a washer and hex nut. Torque to 21 in-lbs.
6. Insert W17 into the rear-panel hole for the I-OUT connector. Secure the cable using a washer and hex nut. Torque to 21 in-lbs.
7. Insert three hole plugs into the three remaining rear-panel holes.
8. Refer to Figure 4 on page 11. Reinstall the serial tag. Torque to 9 in-lbs.
9. Reinstall the line module using the two flat-head screws. Make certain that the ground plug is pointed down. Torque to 9 in-lbs.
10. Reinstall the nut that attaches the green ground wire (A16W2) from the line module to the ground stud on the rear panel. Torque to 9 in-lbs.

Figure 5 Rear panel assembly

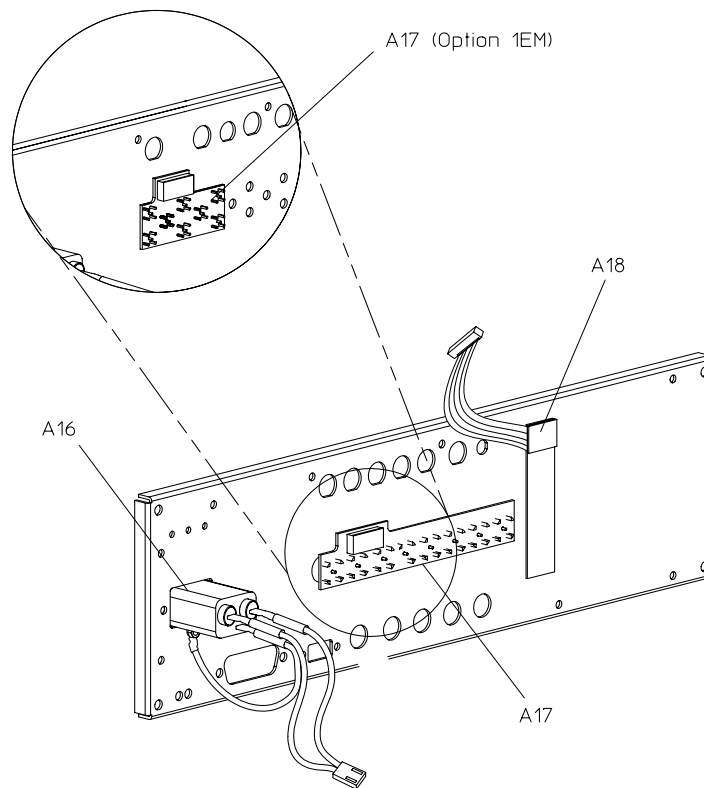

sk7117b

Install the Option UND Rear Panel

1. Refer to Figure 4 on page 11. Attach the new Option UND rear panel to the signal generator chassis with the 10 screws (item 5). Torque to 9 in-lbs.
2. Reinstall the hex screws and washers for the AUXILIARY INTERFACE. Torque to 6 in-lbs.
3. Reinstall the hex screws and washers for the GPIB connector. Torque to 9 in-lbs.
4. Reinstall the nuts and washers securing the BNC connectors at the base of the rear panel. Torque to 21 in-lbs.
5. Reconnect the nut connecting the COHERENT CARRIER cable (W12) to the rear panel. Torque to 9 in-lbs.
6. Reconnect A16W1 to the A4 power supply.
7. Reconnect the bracket at the rear of the signal generator using the two bracket screws.
8. Refer to Figure 3 on page 10. Reinstall the bottom chassis cover with the 15 cover screws. Torque to 9 in-lbs.

Modify the Front Panel

CAUTION Follow all precautions and directions for the safety solvent cleaner.

1. Refer to Figure 6 on page 15. Remove the nut and washer that secure the front panel I INPUT connector to W1.
2. Remove the nut and washer that secure the front panel Q input connector to W2.
3. Remove the existing INPUT overlay from the left side of the front panel. Use the safety solvent cleaner, included in the kit, to remove any remaining glue from the front panel.
4. Align the Option UND overlay with the connector holes. Install the overlay by pressing firmly from the center outward (this prevents air bubbles from forming).
5. Reinstall W1 in the I input connector hole (now located at the top). Attach it to the BNC with a hex nut and spring washer. Torque to 21 in-lbs.
6. Reinstall W2 in the Q input connector hole. Attach it to the BNC with a hex nut and spring washer. Torque to 21 in-lbs.
7. Install W3 in the DATA hole. Attach it to the BNC with a hex nut and spring washer. Torque to 21 in-lbs.
8. Install W4 in the DATA CLOCK hole. Attach it to the BNC with a hex nut and spring washer. Torque to 21 in-lbs.
9. Install W5 in the SYMBOL SYNC hole. Attach it to the BNC with a hex nut and spring washer. Torque to 21 in-lbs.
10. Route all five cables through the cable clamps on the back of the front panel and through the circular grommet in the center of the chassis.

Figure 6 Front Panel

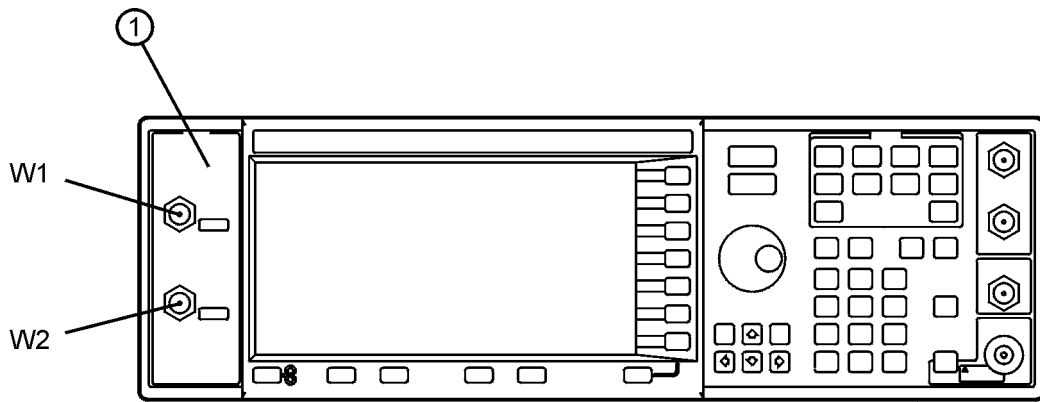

Standard ESG-D Front Panel

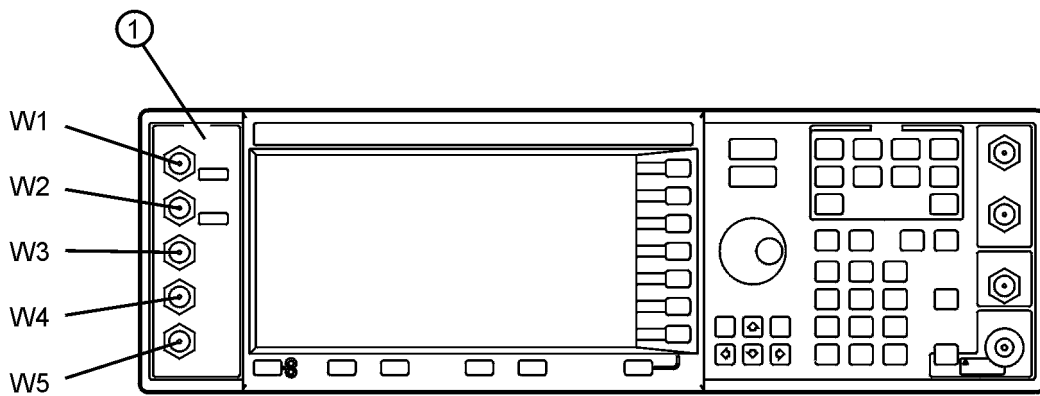

UN8

dk71c

Install Option UND Board Assembly (Options UN3/4 or UN8/9 Not Installed)

1. Cut out a single Option UND label and attach it to the serial tag option location on the rear panel. This identifies the signal generator as having Option UND installed.
2. Refer to Figure 7 on page 17 and the Cable Routing Table on page 19. Insert the A5 dual arbitrary waveform generator board into the motherboard connector labeled A14J1.
3. Connect the ribbon cable, W18, from the A17 rear-panel interface board to the A5 dual arbitrary waveform generator board.
4. Connect W17 from the A5J1 connector on the A5 dual arbitrary waveform generator board to I-OUT on the rear panel.
5. Connect W16 from the A5J2 connector on the A5 dual arbitrary waveform generator board to Q-OUT on the rear panel.
6. Connect W15 from the A5J3 connector on the A5 dual arbitrary waveform generator board to the BASEBAND GEN REF IN connector on the rear panel.

NOTE Refer to the CONNECTOR/CABLE DIAGRAM on the signal generator's RF MODULE CAGE and Figures 7, 8 or 9 on pages 17 and 18 of this installation note for the cable locations. The connector locations (A14P5, A14P6, etc.) are labeled on the A14 motherboard.

7. Connect W3 from DATA to motherboard connector A14P5.
8. Connect W4 from DATA CLOCK to motherboard connector A14P6.
9. Connect W5 from SYMBOL SYNC to motherboard connector A14P7.
10. Connect W26 from motherboard A14P102 to daughter board A15J9 INT I.
11. Connect W25 from motherboard A14P103 to daughter board A15J8 INT Q.
12. Verify cable routings then proceed to "Installing and Verifying the New Firmware" on page 20.

Figure 7 Cable Locations (Option UN3/4 or UN8/9 Not Installed)

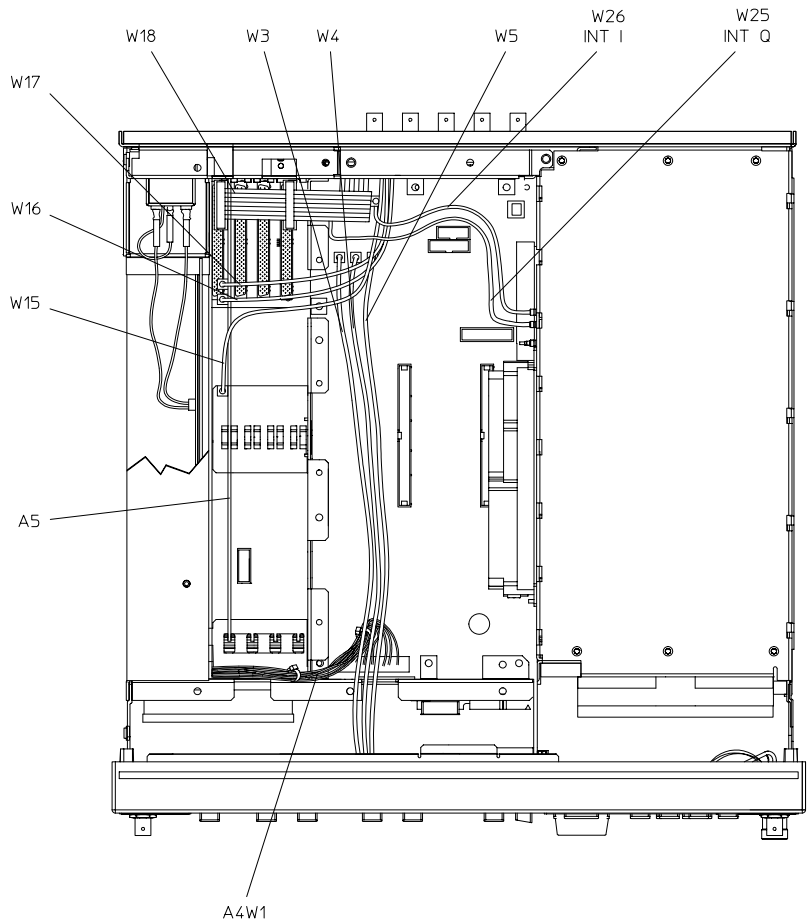

dk73c

Install the Option UND Board Assembly (Options UN3/4 or UN8/9 Installed)

1. Cut out a single Option UND label and attach it to the serial tag option location on the rear panel. This identifies the signal generator as having Option UND installed.
2. Refer to Figure 8 on page 18 and the Cable Routing table on page 19. Insert the A5 dual arbitrary waveform generator board into the motherboard connector labeled A14J1.
3. Connect the ribbon cable, W18, from the A17 rear-panel interface board to the A5 dual arbitrary waveform generator board (if Options UN3/4 are installed) or the A7 real-time I/Q baseband generator (if Option UN8/9 is installed).
4. Disconnect W17 from A7J1 I OUT on the A7 baseband generator board and connect it to A5J1 I OUT on the A5 dual arbitrary waveform generator board.
5. Disconnect W16 from A7J2 Q OUT on the A7 baseband generator board and connect it to A5J2 Q OUT on the A5 dual arbitrary waveform generator board.
6. Disconnect W15 from A7J3 (13 MHz) on the A7 baseband generator board and connect it to A5J3 on the A5 dual arbitrary waveform generator board.
7. Connect W24 between A5J4 and A7J3 (13 MHz).
8. See Figure 8 and Figure 9 on page 18 to verify cable routings.

Figure 8 Cable Locations (Options UN8/9 Installed)

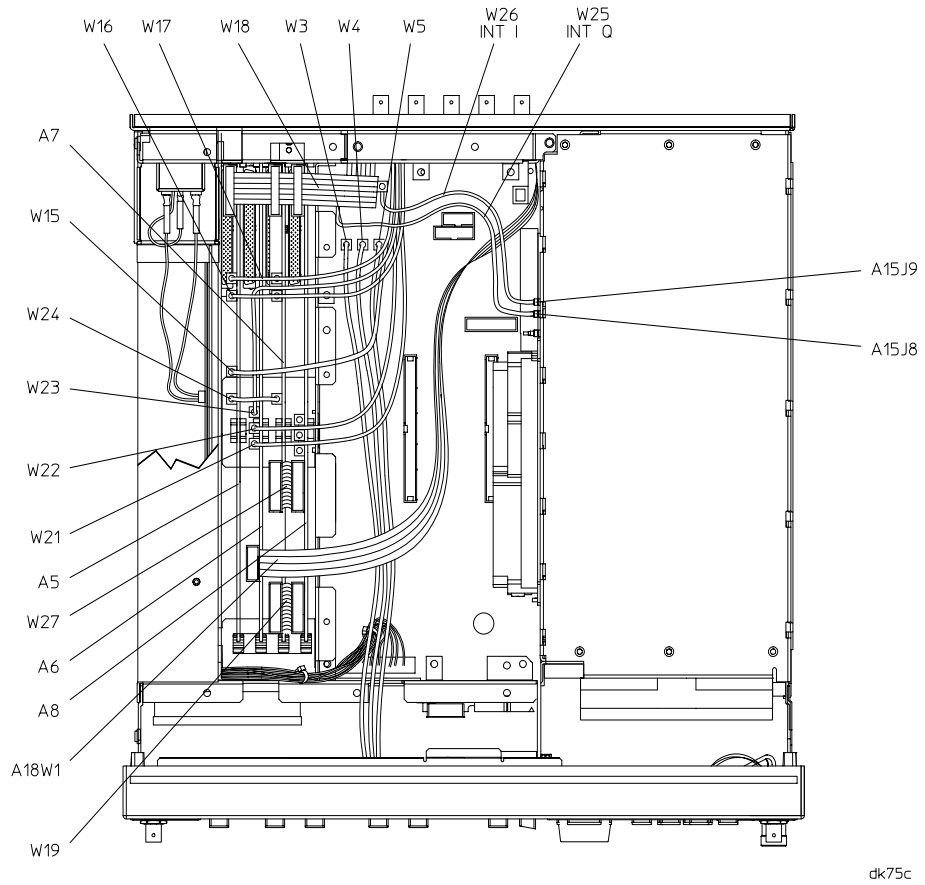

dk75c

Figure 9 Cables W25 and W26

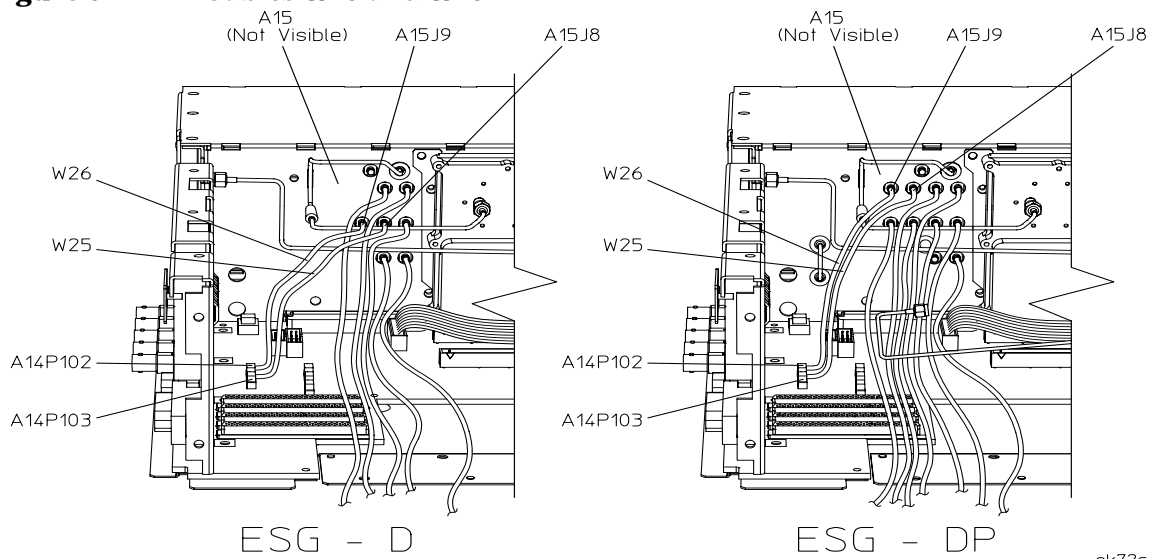

sk72c

Cable Routing (front to rear)

Cable Description	Reference Designator	Color Number ^a	Connection Point to Point
Option UN8 Only (Figure 8 on page 18)			
RIBBON CABLE INTERCONNECT	W19	–	A7P300 to A8P3
RIBBON CABLE INTERCONNECT	W27	–	A7P10 to A8P4
BASEBAND GEN REF IN	W15	8	Rear Panel to A7P403
Q OUT	W16	9	Rear Panel to A7P404
I OUT	W17	09	Rear Panel to A7P405
DATA	W3	5	Front Panel to A14P5
SYMBOL SYNC	W5	6	Front Panel to A14P7
DATA CLOCK	W4	7	Front Panel to A14P6
REAR PANEL INTERFACE CABLE	W18	–	Rear Panel Interface (A17) to A8P2
INT Q	W25	05	Daughter Board (A15) to A14P103
INT I	W26	06	Daughter Board (A15) to A14P102
Option UN8 & Option UN7 (Figure 8 on page 18)			
RIBBON CABLE BERT, REAR PANEL	A18W1	–	Rear Panel to A6P4
BER GATE IN	W21	–	Rear Panel to A6P3
BER CLK IN	W22	–	Rear Panel to A6P2
BER DATA IN	W23	–	Rear Panel to A6P1
Option UN8/9 (Figure 8 on page 18)			
BASEBAND 13 MHz	W24	–	A5J4 to A7J3
BASEBAND GEN REF	W15	–	Rear Panel to A5J3
Q OUT	W16	–	Rear Panel to A5J2
I OUT	W17	–	Rear Panel to A5J1
REAR PANEL INTERFACE CABLE	W18	–	Rear Panel Interface (A17) to A5P1

^a Cable color numbers appear in the CONNECTOR/CABLE DIAGRAM located on the top of the RF MODULE CAGE on the inside cover of the signal generator.

Installing and Verifying the New Firmware

1. Install the new firmware by following the instructions in the firmware upgrade installation note.
2. Perform the verification procedure described in the firmware upgrade installation note.

Activate Option UND

1. Connect the line cord to the signal generator and turn the signal generator line switch on. Let the signal generator warm up for at least 30 minutes.
2. Press **Preset > Utility > Instrument Adjustments > Hardware Options**.
3. Highlight **Option UND** by using the arrow keys, or front-panel knob.
4. Press **Select Item**. An **X** will be placed in the “selected” column.
5. Press **Proceed With Reconfiguration > Confirm Change** to install Option UND. The signal generator will reboot and return to factory preset conditions.

Reinstall the Signal Generator top chassis and top covers

1. Turn the signal generator's power switch off and disconnect the line cord.
2. Refer to Figure 2 on page 9. Reinstall the signal generator top chassis cover with the 11 top chassis cover screws. Torque the screws to 9 in-lbs.
3. Slide the signal generator cover onto the chassis.
4. Replace the four rear feet. Torque the rear feet screws to 21 in-lbs.
5. Replace the bottom four feet.
6. Replace the two strap handles with the four strap handle screws. Torque to 21 in-lbs.

Calibrate the Signal Generator and Verify Performance

1. Turn the signal generator on.
2. Press **Preset > Utility > Instrument Adjustments > Hardware Options > Calibrate Selected Items**.
3. Press **Start Calibration and Store Results**. The calibration takes several minutes.
4. Perform the “Dual Arbitrary Waveform Generator Check” located in the Performance Tests section of the calibration guide for your signal generator.

NOTE If you get an error message, please refer to the *Error Messages Guide*, E4400-90333, for an explanation of the error message. The *Error Messages Guide* can be found online at: <http://www.agilent.com/find/esg>.
